



XVL | Express technology





The XVL line is an important collection of compact, robust floor-standing machines for producing express gelato using the best technologies:

Based on Carpigiani Experience

The Italian company with the widest range of express and artisan gelato machines in the world.

Very Versatile

Because they can produce very different gelato types at the same time, like rich milk-based gelato and delicate fruit sorbets.

Large Production Capacity

With its long cylinders, XVL guarantees continuous production, even during peak hours.

Gelato Quality



MIXES REMAIN FLUID

The mixes in the refrigerated hoppers are continuously blended by mixers to maintain a fluid consistency, thus guaranteeing a constant flow into the cylinders.



CREAMY, SOFT GELATO

The XVL/P has a gear pump that injects air pressure into the mix and feeds the production cylinders, resulting in a gelato with high overrun, up to 80%. Inside the cylinders, beaters with double spirals and an idler produce a soft, creamy gelato.



FIRM, DRY GELATO

The XVL/G uses gravity to feed the cylinders. Control valves naturally add air to the mix producing a gelato having an overrun of up to 40%. Inside the cylinders, one-piece POM beaters produce a gelato that is firm and dry.

Easy to use



CONTROL PANEL

The control panel is positioned at eye level to facilitate program selection. The intuitive graphics facilitate rapid use of the touchpad.



LARGE PRODUCTION SPACE

The 10 cm space for dispensing makes it possible to easily produce large cups and fill molds for takeout products like cakes, logs, cassate, gelato sandwiches, and so on.



PRECISION DISPENSING

With the two optional smooth and serrated nozzles it is possible to rapidly fill cups, tartlets, cannoli, cookies, and produce stunning gelato treats and pastries.

Performance and Savings

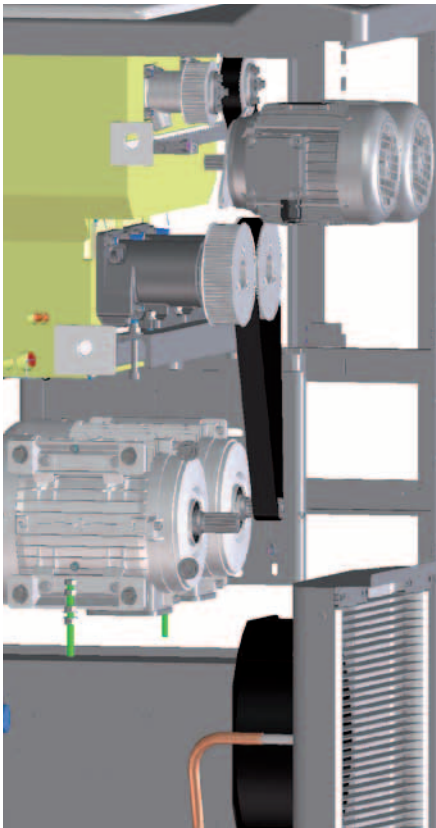

PRODUCE MILK-BASED GELATO AND FRUIT SORBETS AT THE SAME TIME

In the double machines, each cylinder has its own refrigeration system and each beater its own dedicated motor. In the XVL/P, each pump has its own motor, which runs only when the corresponding cylinder is being used to produce gelato. This separation makes it possible to calibrate production independently and freeze mixes that are very different from each other at the same time, like milk- or fruit-based gelato and frozen yogurt.

USE JUST ONE MACHINE

The double machines can have one side turned off, essentially transforming them into single machines with one lever - quite useful in low season.



PREPARE MIX IN THE HOPPER

Thanks to the Dry Filling option, it is possible to add water and dry mix directly into the hopper and use the mixer to dissolve the powdered bases, a fast and simple solution for preparing mixes.



GELATO SWIRLS READY IN AN INSTANT

Using the optional mixer installed next to the dispensers, toppings like nuts, chocolate chips and many others can be quickly swirled into the gelato.



SELF-CLOSING DISPENSERS

The dispensers close automatically. If a lever is released during dispensing, it will automatically close on its own, stopping the flow of gelato.



ALUMINUM PINLESS LEVERS

When the machine is not being used, the levers can be easily removed and then replaced without the use of any tools.

Hygiene and Safety

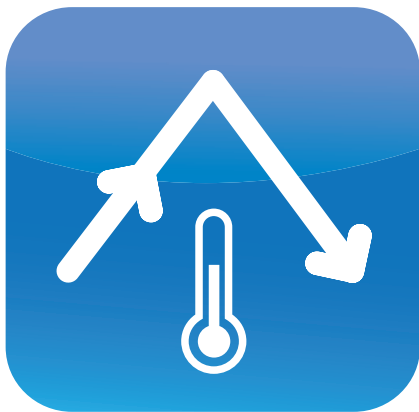

MONTHLY MACHINE CLEANING

All XVL models, pump and gravity fed, can be equipped with an **auto-matic SP self-pasteurization system**. This process sanitizes the mix and all parts that come into contact with the gelato, usually during the night when the machine is at rest, keeping the mix safe and the machine clean. **The SP function makes it possible to allow up to 42 days between scheduled disassembly and cleaning.**



REMOTE MAINTENANCE VIA INTERNET

The XVL machine is preconfigured for Internet connection to the TEOREMA remote maintenance system. This exclusive service from Carpigiani makes it possible to monitor the machines via computer, tablet, or smartphone, facilitating technical assistance and ensuring uninterrupted production.

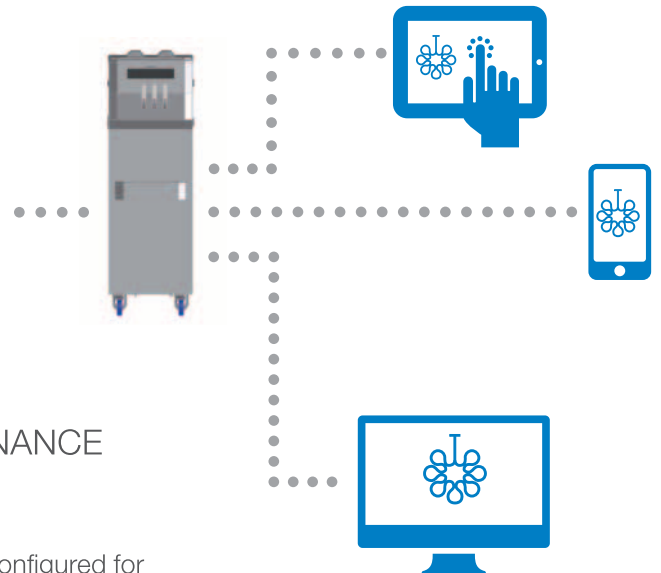

Dimensions	XVL 1	XVL 3
Width cm.	45	50
Depth cm.	70,5	70,5
Height cm.	160,5	160,5

Installation Spacing:
 Side spacing: 40 cm
 Rear spacing: 40 cm

Technical Specifications

Model	Levers	Flavors	Feed	Overrun %	Production Kg / hour	Cones 75 g / hour	Hopper capacity (Lt)	Volt	Hz	Ph	kW	Cool	Weight Kg
XVL 1/G	1	1	Gravity	30 ÷ 40	38	500	13	400	50	3	2,7	Air	225
XVL 1/P	1	1	Pump	40 ÷ 80	38	500	13	400	50	3	2,7	Air	230
XVL 3/G	3	2+1	Gravity	30 ÷ 40	50	670	13 + 13	400	50	3	4,7	Air	300
XVL 3/P	3	2+1	Pump	40 ÷ 80	50	670	13 + 13	400	50	3	4,7	Air	310

Production time depends on the mix used and the room temperature.

XVL can be configured with these optionals

SP = Self Pasteurizing	Nozzles for gelato treats	M = Mixer	DF = Dry Filling	W = Water cooling
------------------------	---------------------------	-----------	------------------	-------------------

XVL machines are produced by Carpigiani using a UNI EN ISO 9001 Certified Quality System.

All specifications mentioned must be considered approximate. Carpigiani reserves the right to modify; without notice, all parts deemed necessary.

Dealer



Carpigiani
helps you smile!



Via Emilia, 45 - 40011 Anzola dell'Emilia BOLOGNA, Italy Tel. +39 051 6505111 carpigiani.com

